



COMPACT 8 W COMPACT 10 / 12

Exceptional productivity

- Load capacity up to 450 kg (C8W and C10)
- Driveable at full height
- Both inside and outside use with the same load capacity
- Extended platform
- Width of 1.20 m
- Long working cycles

Robust, reliable, easy to maintain





COMPACT 8 W / 10 / 12

ELECTRIC SCISSOR LIFTS

TECHNICAL DATA

	Compact 8 W	Compact 10	Compact 12
Working height	8.25 m	10.15 m	12 m
Platform height	6.25 m	8.15 m	10 m
Driveable at full height up to	6.25 m	8.15 m	10 m
Lift capacity - inside	450 kg	450 kg	300 kg
Lift capacity - outside	450 kg	450 kg	300 kg
A Platform length - outside	2.3 m	2.3 m	2.3 m
B Platform length - extended	3.22 m	3.22 m	3.22 m
Length - extension	0.92 m	0.92 m	0.92 m
C Platform width - outside	1.2 m	1.2 m	1.2 m
E Storage height	1.28 m	1.4 m	1.53 m
D Height - stowed	2.14 m	2.26 m	2.38 m
F Overall width	1.2 m	1.2 m	1.2 m
G Length	2.45 m	2.45 m	2.45 m
H Wheelbase	1.86 m	1.86 m	1.86 m
I Ground clearance - Centre	13 cm	13 cm	13 cm
Ground clearance - Pothole guards deployed	2.5 cm	2.5 cm	2.5 cm
Drive speed	1 - 3.5 km/h	1 - 3.5 km/h	0.9 - 3.5 km/h
Gradeability	23 %	23 %	23 %
Tilt	2 °	2 °	2 °
Lift / lower speed	56 s / 44 s	51 s / 42 s	83 s / 52 s
Turning radius - outside	2.5 m	2.5 m	2.5 m
Tyres - non marking	15x5	15x5	15x5
Batteries	24 V - 255 Amph (C5)	24 V - 255 Amph (C5)	24 V - 255 Amph (C5)
Hydraulic system capacity	25 l	25 l	25 l
Weight	1950 kg	2330 kg	2470 kg

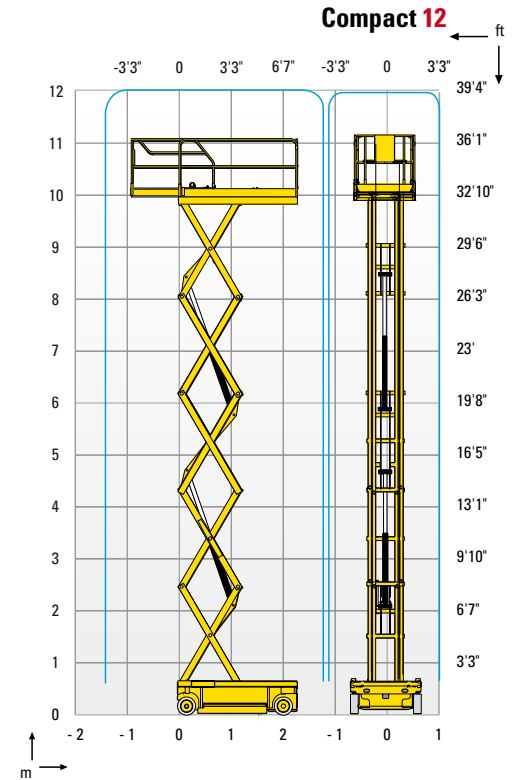

STANDARD EQUIPMENT

- ③ Pothole guards
- ③ Battery charge indicator
- ③ Proportional lift and drive
- ③ Removable control box in platform
- ③ Swing out component tray
- ③ Battery charger with automatic stop
- ③ Solid non-marking tyres
- ③ Free wheeling device
- ③ Tilt controller
- ③ Load Management System in the platform
- ③ Manual platform lowering valve
- ③ Integrated forklift pockets
- ③ Towing hooks
- ③ Horn
- ③ Hourmeter

OPTIONS AND ACCESSORIES

- ③ Flashing light
- ③ Travel alarm
- ③ Working light
- ③ Power to platform
- ③ Biodegradable hydraulic oil
- ③ Folding guardrails
- ③ Maintenance-free batteries
- ③ Traction batteries
- ③ Centralised battery filling

